

SPECIFICATIONS:

CONTROL FREQUENCIES	40Hz, 150Hz, 400Hz, 1KHz, 3.5KHz, 8KHz AND 15KHz
EQUALIZATION RANGE	BOOST 12dB+/-3dB, CUT 12dB+/-3dB
INPUT SINGAL VOLTAGE	5V(High) / 800mV(Low)
FREQUENCY RESPONSE	20Hz~20KHz
DISTORTION	<0.01%
S/N RATIO	>60dB
CHANNEL SEPARATION	>50dB
DIMENSION	178 X 25 X 141MM
CONSUMPTION	250mA
POWER SUPPLY	11-16DC NEGATIVE GROUND.

Due to our continuing efforts towards products improvement, the above specification are subject to change without notice.

CARE AND MAINTENANCE

Your Pyramid Stereo 7-Band Graphic / Equalizer is an example of superior design and craftsmanship. The following suggestions will help you care for your equalizer / booster so you can enjoy it for years.



Keep the graphic / equalizer dry. If it does get wet, wipe it dry immediately. Liquids contain minerals that can corrode electronic circuits.



Keep the graphic / equalizer away from dust and dirt, which can cause premature wear of parts.



Use and store the graphic / equalizer only in normal temperature environments. Temperature extremes can shorten the life of electronic devices and distort or melt plastic parts.



Wipe the graphic / equalizer with a damp cloth occasionally to keep it looking new. Do not use harsh chemicals, cleaning solvents, or strong detergents to clean the graphic / equalizer.



Handle the graphic / equalizer gently and carefully. Dropping it can damage the circuit boards and can cause it to work improperly.

PYRAMID®

Gold Series

**OWNER'S
MANUAL**



MODEL: 714EX
HALF-DIN
7 BAND PRE-AMP EQUALIZER
WITH SUB WOOFER OUTPUT

FEATURES

- 7 BANDS PASSIVE EQ WITH SUB-WOOFER PRE-AMP OUTPUT
- SUB-WOOFER FREQUENCY SELECT SWITCH (80Hz OR 120Hz)
- SUB-WOOFER OUTPUT LEVEL CONTROL AND ON/OFF SWITCH
- HIGH/LOW LEVEL INPUT (LOW LEVEL INPUT WITH 2 GOLD PLATED RCA)
- 3.5MM CD INPUT JACK AND AUTO CUT OFF HIGH / LOW LEVEL INPUT
- 4 GOLD PLATED RCA FOR EQ PRE-AMP OUTPUT (FL/ FR /RL AND RR)
- 2 GOLD PLATED RCA FOR SUB-WOOFER PRE-AMP OUTPUT
- EQ FUNCTION ON/ OFF SWITCH
- FRONT / REAR FADER CONTROL
- REMOTE POWER ON/ OFF WITH INDICATOR
- LEFT / RIGHT INPUT SIGNAL LEVEL METER
- LIGHT ILLUMINATION

CONTROLS:

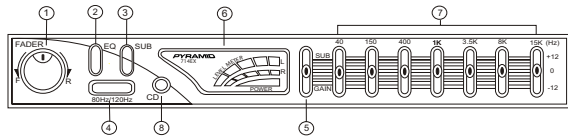

1. FADER
2. EQ SWITCH
3. SUB-WOOFER SWITCH
4. SUB-WOOFER CROSSOVER POINTS
5. ADJUSTABLE SUB-WOOFER GAIN CONTROL
6. OUTPUT LEVEL DISPLAY
7. EQ SLIDE CONTROLS
8. COMPACT DISC INPUT-PUT JACK

OPERATION

1. FADER
Allows front to rear balancing in four speaker systems for best directional imaging.
2. EQ SWITCH
Press in to engage the equalizer circuitry. Press it (outer position) the result is the same as setting all slide controls to center position. It is useful in judging the result of your EQ Settings.
3. SUBWOOFER SWITCH
When the subwoofer is connected, use this switch to activate/deactivate the subwoofer.
4. SUBWOOFER CROSSOVER POINTS
Two operating modes. The SUBWOOFER MODE activates an internal low-pass filter, so only the deepest bass notes are passed to the woofer system. Two position 80Hz or 120Hz.
5. ADJUSTABLE SUBWOOFER GAIN CONTROL
Allows user to adjust subwoofer output to match overall system output.
6. OUTPUT LEVEL DISPLAY
A dual three-color LED Display shows the instantaneous, peak level for the frequency content of the source music, adding yet another dimension to your visual enjoyment.
7. EQ SLIDE CONTROLS
Each slide controls the amount of boost or cut in one small part of the total audio frequency range. With all slides in the center position, the overall frequency response is flat. By moving any slide up or down, the output within the band is increased or decreased by up to 12 dB.
8. COMPACT DISC IN-PUT JACK
Using 3.5mm jack and cable, plugging into CD in-put jack from any external portable CD player will automatically cut off the low level input and transmits the CD signal to the outlet.

2.

ELECTRICAL CONNECTIONS

The EQUALIZER is designed for in-dash installation directly above or below a standard DIN sized radio / tape player. Installation Kits for the purpose are available from a variety of suppliers. Consult with a professional Autosound installer for assistance.

Each wire is individually labeled to reduce any chance of error. Phono cable pairs with plugs on both ends are required to connect the EQUALIZER outputs to the remote amplifiers and also for the phono inputs if used. These can be purchased from a local audio dealer in the correct lengths for your particular installation.

The Black wire labeled Power Ground is connected directly to the vehicle chassis.

The Red wire with in-line fuse is the main power input to the EQUALIZER. It should be connected to a source of Switched +12 Volts (Cut off by the Ignition switch). This is normally the same fuse-panel terminal that powers your radio.

The Orange wire is used to turn the EQUALIZER On. It should be connected to the in-dash radio's Power Antenna Output Lead.

The final step in the electrical installation is to connect the Left & Right Output signals from your radio to the EQUALIZER inputs in one of two ways, depending on how your radio is equipped. If it has Phono-style Line Outputs, then they are connected to the matching Line Inputs using a purchased cable pair as discussed above.

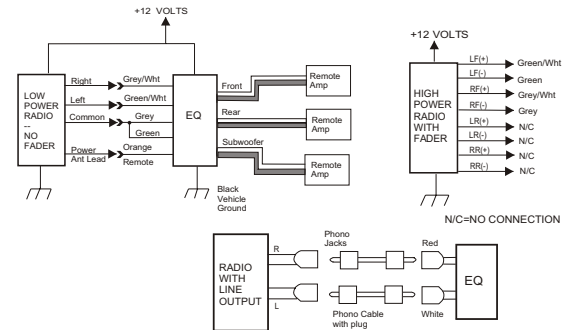

3.